

# PARTY

Sistema a barre attrezzate  
Système de barres équipées  
Equipped bars system  
einreicht Stangensystem  
Sistema de barras equipadas

PARTY è un sistema a barre di sostegno orizzontale, per pannellature o a muro, equipaggiato con accessori agganciabili e liberamente posizionabili sui profili. Tutti i profili sono realizzati in alluminio estruso anodizzato naturale. Tutte le attrezzature hanno finitura in alluminio anodizzato naturale o verniciato nei colori a cartella. PARTY si installa con rapidità e sicurezza. Il sistema si completa con i necessari profili di finitura. Con PARTY ogni ambiente consegue qualcosa di più facile e più utile.

PARTY est un système de barres de support horizontal, pour panneautages ou mural, équipé d'accessoires à accrocher pouvant être positionnés librement sur les profilés. Tous les profilés sont réalisés en aluminium extrudé anodisé naturel. Tous les accessoires ont une finition en aluminium anodisé naturel ou laqué dans les couleurs du catalogue. PARTY s'installe avec rapidité et sûreté. Le système est complété par d'indispensables profilés de finition. PARTY, c'est ce qu'il y a de plus facile et de plus utile pour un intérieur.

PARTY is a system of horizontal support bars to be used in panelling or against the wall, equipped with hook-on accessories, and can be positioned at will on the profiles. All the profiles are made of natural anodised extruded aluminium. All the fittings have a natural anodised finish or are lacquered in one of the colours available from the colour collection. PARTY is quick and easy to install. The system is completed by the necessary finishing profiles. With PARTY, all your surroundings acquire something easier and more useful.

PARTY ist ein horizontales Stützprofilssystem für Paneele oder für die Positionierung an Wänden, mit einhängbarem und frei in den Profilen positionierbarem Zubehör. Alle Profile sind aus fließgepreßtem eloxiertem Natur-Aluminium. Alle Zubehörteile sind in der Ausführung eloxiertes Natur-Aluminium oder in den Farben der Farbtabelle lackiert. PARTY läßt sich schnell und sicher anmontieren. Das System wird mit den entsprechenden Abschlußprofile vervollständigt. Mit PARTY wird jedes Ambiente bequemer und nützlicher.

PARTY es un sistema de barras de sostén horizontal, para paneles o de pared, equipado con accesorios que se enganchan y se posicionan libremente en los perfiles. Todos los perfiles son de aluminio extruído anodizado natural. Todos los elementos son de aluminio anodizado natural o pintado en los colores del muestrario. PARTY se instala con rapidez y seguridad. El sistema se completa con los necesarios perfiles de acabado. PARTY, además de ser útil, se adapta a cualquier ambiente con facilidad.

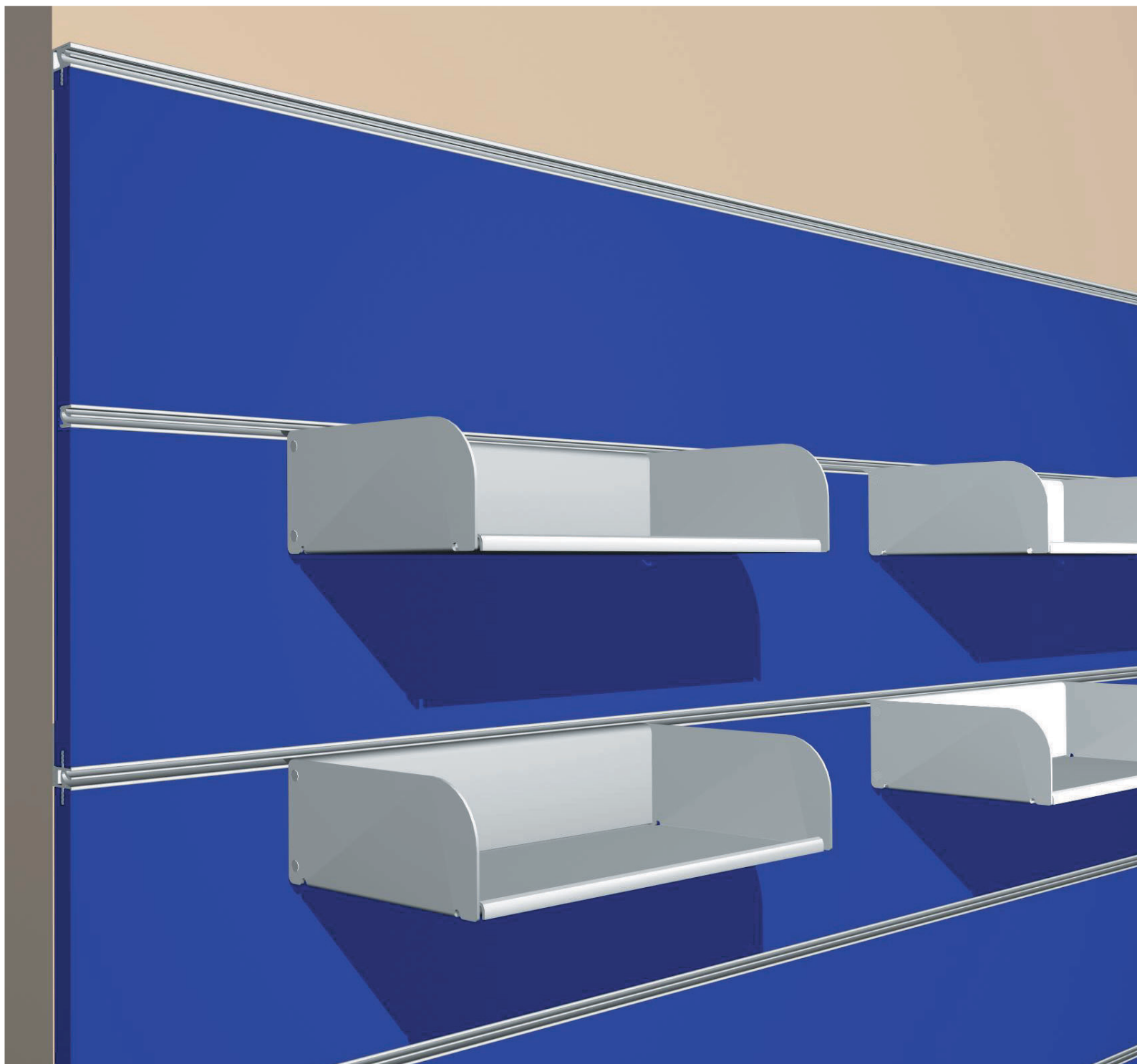

# CAIMIDUE

CAIMI EXPORT 2 s.p.a.  
60030 Monsano (Ancona) Italia  
via Cassolo 22-24  
phone + 39 0731 61951 • fax + 39 0731 619520  
www.caimidue.com

DESCRIZIONE  
DESCRIPTION  
DESCRIPTION  
BESCHREIBUNG  
DESCRIPCION

DESCRIZIONE  
DESCRIPTION  
DESCRIPTION  
BESCHREIBUNG  
DESCRIPCION

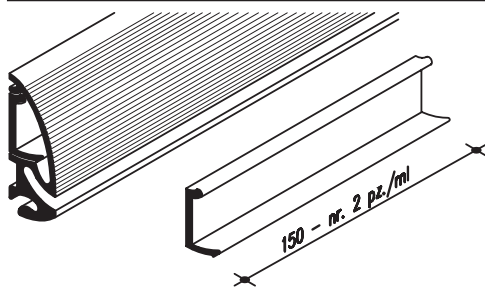

**Profilo di sostegno a muro**  
**Profilé de support mural**  
**Wall support profile**  
**Stützprofil für die Wand**  
**Perfil de sostén de pared**

barre 4 ml.  
barres 4 ml.  
barres 4 ml.  
bars 4 ml.  
barras 4 ml.

**Y150**

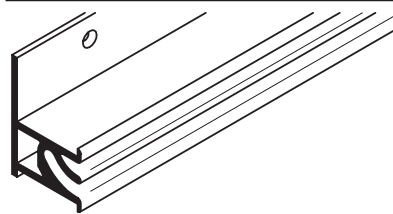

**Profilo di sostegno intermedio**  
**Profilé de support intermédiaire**  
**Middle support profile**  
**Zwischenprofil**  
**Perfil di sostén intermedio**

per pannello 16 mm (barre 4 ml.)  
pour panneau 16 mm (barres 4 ml.)  
for panel 16 mm (barres 4 ml.)  
für Paneele 16 mm (bars 4 ml.)  
para panel 16 mm (barras 4 ml.)

**Y125**

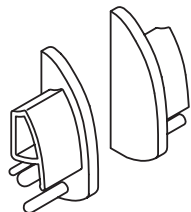

**Coppia tappi terminali**  
**Paire d'embouts finals**  
**Pair of end caps**  
**Abschlußkappen (Paar)**  
**Par de tapones terminales**

per/pour/for/für/por art.Y150 **Y151**

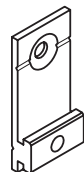

**Supporto**  
**Support**  
**Support**  
**Halterung**  
**Sostén**

per/pour/for/für/por art.Y120 **Y121**

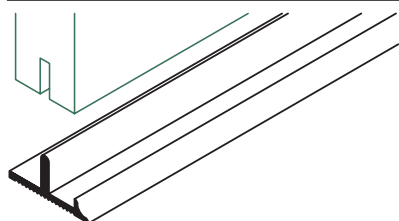

**Profilo inferiore**  
**Profilé inférieur**  
**Lower profile**  
**Unteres Profil**  
**Perfil inferior**

per pannello 19 mm (barre 4 ml.)  
pour panneau 19 mm (barres 4 ml.)  
for panel 19 mm (barres 4 ml.)  
für Paneele 19 mm (bars 4 ml.)  
para panel 19 mm (barras 4 ml.)

**Y100**

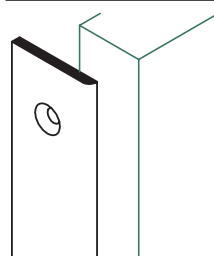

**Profilo laterale di chiusura**  
**Profilé latéral de fermeture**  
**Fastener lateral profile**  
**seitliches Abschlußprofil**  
**Perfil lateral de cierre**

per pannello 19 mm/pour panneau 19 mm  
for panel 19 mm/für Paneele 19 mm/para panel 19 mm

fissaggio a vite/fixation avec vis/fastening with screws  
Schraubenbefestigung/sujeción con tornillos

barre/barres/Bars/barras 2,5 ml **Y130**

barre/barres/Bars/barras 3,0 ml **Y136**

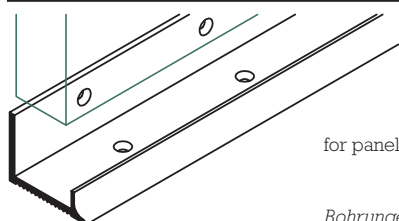

**Profilo inferiore**  
**Profilé inférieur**  
**Lower profile**  
**Unteres Profil**  
**Perfil inferior**

per pannello 16 mm/pour panneau 16 mm  
for panel 16 mm/für Paneele 16 mm/para panel 16 mm

foratura a richiesta  
perçage à la demande/Bore-holes on request  
Bohrungen auf Wunsch/agujeros realizados bajo pedido

**Y105**

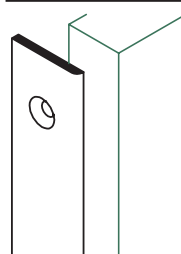

**Profilo laterale di chiusura**  
**Profilé latéral de fermeture**  
**Fastener lateral profile**  
**seitliches Abschlußprofil**  
**Perfil lateral de cierre**

per pannello 16 mm/pour panneau 16 mm  
for panel 16 mm/für Paneele 16 mm/para panel 16 mm

fissaggio a vite/fixation avec vis/fastening with screws  
Schraubenbefestigung/sujeción con tornillos

barre/barres/Bars/barras 2,5 ml **Y135**

barre/barres/Bars/barras 3,0 ml **Y137**

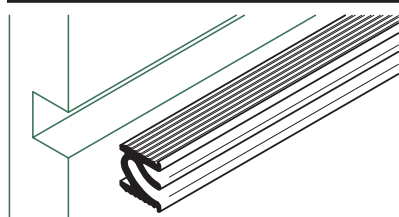

**Aggancio a schienale**  
**Profilé d'accrochage pour panneau**  
**Rear hooking**  
**Profileinsatz an Paneelen**  
**Perfil de engache en trasera**

barre 4 ml.  
barres 4 ml.  
barres 4 ml.  
bars 4 ml.  
barras 4 ml.

**Y110**

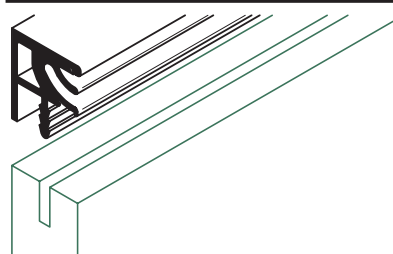

**Profili di sostegno superiori**  
**Profilés de support supérieurs**  
**Top support profiles**  
**oberes Profil**  
**Perfiles de sostén superiores**

per pannello 19 mm (barre 4 ml.)  
pour panneau 19 mm (barres 4 ml.)  
for panel 19 mm (barres 4 ml.)  
für Paneele 19 mm (bars 4 ml.)  
para panel 19 mm (barras 4 ml.)

**Y140**

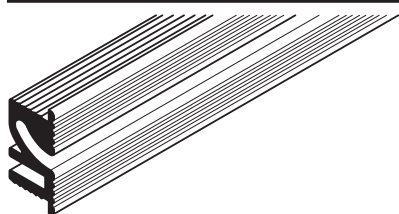

**Profilo di sostegno intermedio**  
**Profilé de support intermédiaire**  
**Middle support profile**  
**Zwischenprofil**  
**Perfil di sostén intermedio**

barre 4 ml.  
barres 4 ml.  
barres 4 ml.  
bars 4 ml.  
barras 4 ml.

**Y115**

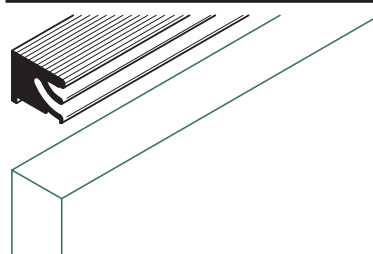

**Profili di sostegno superiori**  
**Profilés de support supérieurs**  
**Top support profiles**  
**oberes Profil**  
**Perfiles de sostén superiores**

per pannello 16 mm (barre 4 ml.)  
pour panneau 16 mm (barres 4 ml.)  
for panel 16 mm (barres 4 ml.)  
für Paneele 16 mm (bars 4 ml.)  
para panel 16 mm (barras 4 ml.)

**Y145**

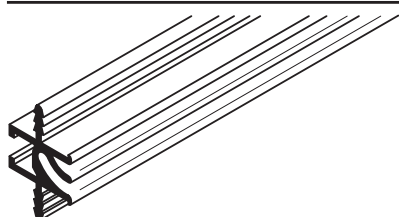

**Profilo di sostegno intermedio**  
**Profilé de support intermédiaire**  
**Middle support profile**  
**Zwischenprofil**  
**Perfil di sostén intermedio**

per pannello 19 mm (barre 4 ml.)  
pour panneau 19 mm (barres 4 ml.)  
for panel 19 mm (barres 4 ml.)  
für Paneele 19 mm (bars 4 ml.)  
para panel 19 mm (barras 4 ml.)

**Y120**

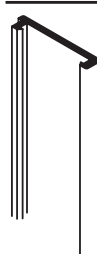

**Profilo laterale di chiusura**  
**Profilé latéral de fermeture**  
**Fastener lateral profile**  
**seitliches Abschlußprofil**  
**Perfil lateral de cierre**

per pannello 19 mm/pour panneau 19 mm  
for panel 19 mm/für Paneele 19 mm/para panel 19 mm

montaggio con/montage avec/hook up with  
Montage mit/montage con/ art.Y132

barre/barres/Bars/barras 2,5 ml **Y131**

barre/barres/Bars/barras 3,0 ml **Y134**

DESCRIZIONE  
DESCRIPTION  
DESCRIPTION  
BESCHREIBUNG  
DESCRIPCION

DESCRIZIONE  
DESCRIPTION  
DESCRIPTION  
BESCHREIBUNG  
DESCRIPCION



**Supporto  
Support  
Halterung Kunststoff  
Sostén**  
plastica  
plastique  
plastic  
Plastik  
plástico

per/pour/for/für/por art.Y131 **Y132**

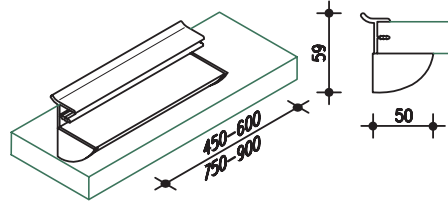

**Reggimensola per legno  
Support d'étagère en bois  
Wooden shelf-holder  
Holzkonsolenträger  
Sostén para estante de madera**  
(25 mm)

450 mm **Y700** 600 mm **Y710**  
750 mm **Y720** 900 mm **Y730**

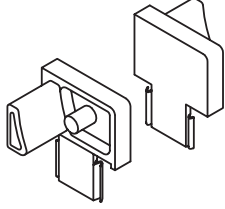

**Giunto angolare superiore  
Joint d'angle supérieur  
Upper angle coupling  
oberer Winkelabschluss Kunststoff  
Unión angular superior**  
plastica  
plastique  
plastic  
Plastik  
plástico

per/pour/for/für/por art.Y140 / 141 **Y133**

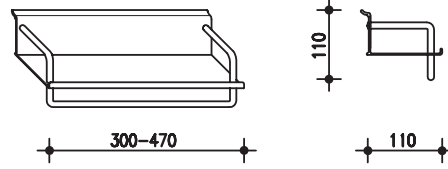

**Mensola  
Etagère  
Shelf  
Konsole  
Estante**

300 mm **Y751**  
470 mm **Y752**

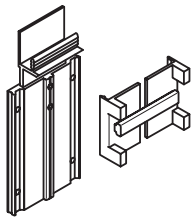

**Kit piedino regolabile per zoccoli  
Kit pied réglable pour plinthes  
Plinth adjustable foot kit  
Kit regulierbare Füße für Sockel  
Juego pata ajustable para zócalos**

**Y160**

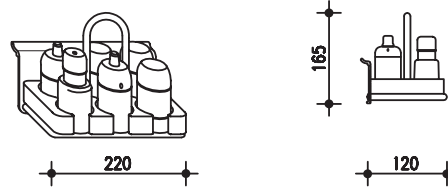

**Table set  
Table set  
Table set  
Gewürzständer  
Vinagreras**

**Y760**

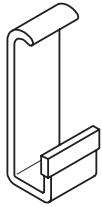

**Distanziale per mensole  
Entretoise pour étagères  
Shelf spacer  
Distanzhalter für Konsolen  
Distanciador para estantes**

per/pour/for/für/por art.Y150 **Y152**

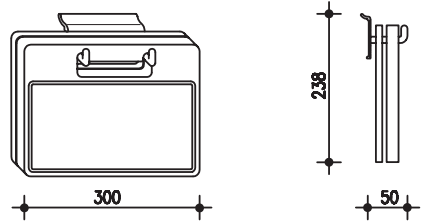

**Mensola con 2 taglieri  
Tablette avec 2 planches  
à découper  
Shelf with 2 chopping-boards  
Konsole mit 2 Schneidebrettern  
Estante con 2 tajos de cocina**

**Y771**

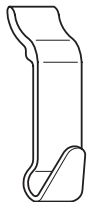

**Gancio in alluminio  
Crochet en aluminium  
Aluminium hook  
Aluminiumhaken  
Gancho de aluminio**

**Y210**

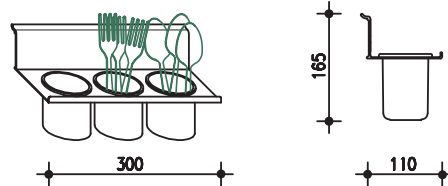

**Portaposate  
Porte-couverts  
Cutlery holder  
Besteckhalter  
Portacubiertos**

**Y810**

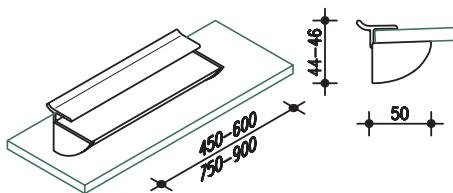

**Reggimensola per cristallo  
Support d'étagère en verre  
Crystal shelf-holder  
Glasskonsolenträger  
Sostén para estante de cristal**  
(8/10 mm)

450 mm **Y600** 600 mm **Y610**  
750 mm **Y620** 900 mm **Y630**

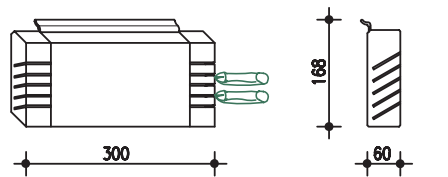

**Portacoltelli in legno  
Porte-couteaux en bois  
Knife holder in wood  
Messerblock aus Holz  
Portacuchillos de madera**

**Y821**

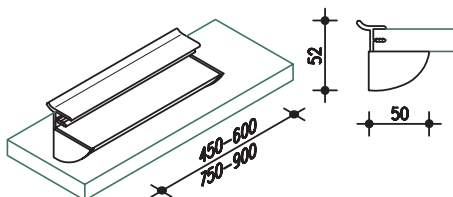

**Reggimensola per legno  
Support d'étagère en bois  
Wooden shelf-holder  
Holzkonsolenträger  
Sostén para estante de madera**  
(18 mm)

450 mm **Y650** 600 mm **Y660**  
750 mm **Y670** 900 mm **Y680**

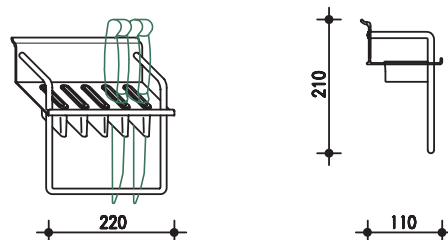

**Portacoltelli  
Porte-couteaux  
Knife holder  
Messerhalter  
Portacuchillos**

**Y822**

DESCRIZIONE  
DESCRIPTION  
DESCRIPTION  
BESCHREIBUNG  
DESCRIPCION

DESCRIZIONE  
DESCRIPTION  
DESCRIPTION  
BESCHREIBUNG  
DESCRIPCION

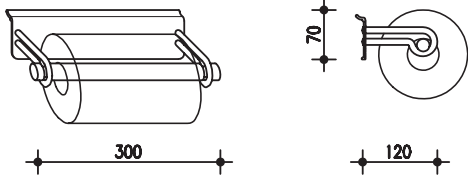

**Portarotoli**  
Porte-rouleaux de papier  
Roll holder  
Küchenrollenhalter  
Distribuidor de papel de cocina)

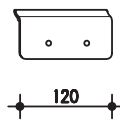

**Profilo di aggancio per elementi in legno (esclusi)**  
Profilé d'accrochage pour les éléments en bois (exclus)  
Profile hooking for wooden elements (excluded)  
Hakenleiste für Holzelemente (ohne Elemente)  
Perfil de enganche para elementos en madera (excluidos)

**Y830**

**Y781**

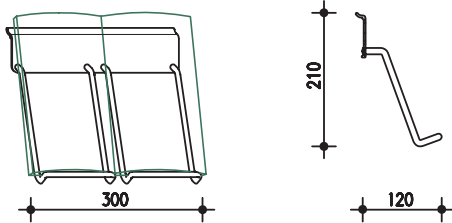

**Leggio**  
Pupitre  
Book-rest  
Lesepult  
Atril

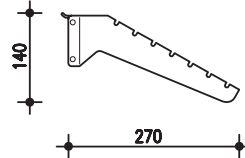
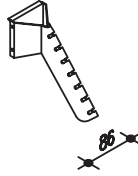

**Portagrucce**  
Porte-cintres  
Clothes-hanger rack  
Kleiderbügelträger  
Portaperchas

**Y850**

**Y900**

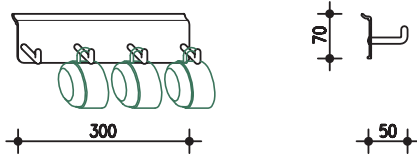

**Mensola portatazze**  
Étagère porte-tasses  
Cup-holding shelf  
Tassenbord  
Estante portatazas

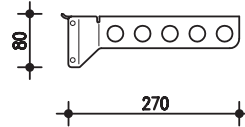
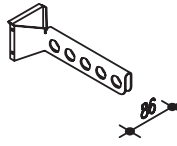

**Portagrucce**  
Porte-cintres  
Clothes-hanger rack  
Kleiderbügelträger  
Portaperchas

**Y860**

**Y917**

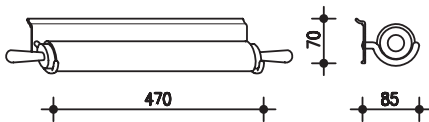

**Portamattarello con mattarello**  
Porte-rouleau avec rouleau  
Rolling-pin holder with rolling-pin  
Nudelholzhalter mit Nudelholz  
Portarrodillo con rodillo

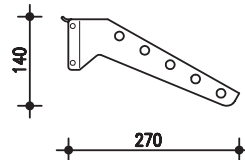
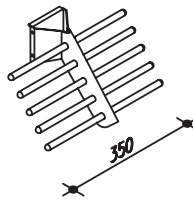

**Portacravatte**  
Porte-cravates  
Tie rack  
Krawattenhalter  
Portacorbatas

**Y870**

**Y901**

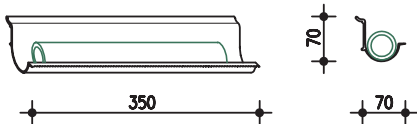

**Porta film a strappo**  
Porte-film à détacher  
Tearing film wrap holder  
Folienrollenhalter  
Portapelícula de tirón

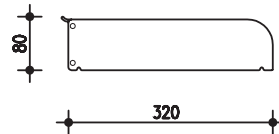
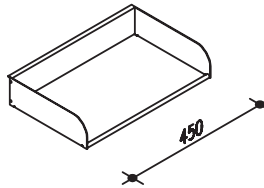

**Mensola**  
Étagère  
Shelf  
Ablagebrett  
Estante

**Y880**

**Y902**

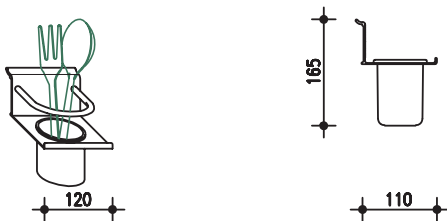

**Portaspatole**  
Porte-brosses  
Spatula-holder  
Küchenschaberhalter  
Portautensilios

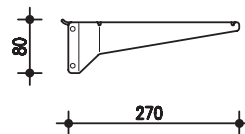
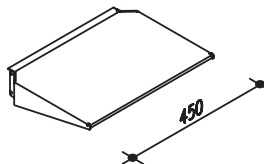

**Mensola**  
Étagère  
Shelf  
Ablagebrett  
Estante

**Y890**

**Y914**

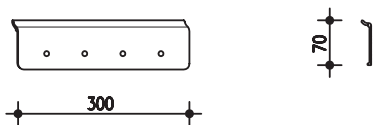

**Profilo di aggancio per elementi in legno (esclusi)**  
Profilé d'accrochage pour les éléments en bois (exclus)  
Profile hooking for wooden elements (excluded)  
Hakenleiste für Holzelemente (ohne Elemente)  
Perfil de enganche para elementos en madera (excluidos)

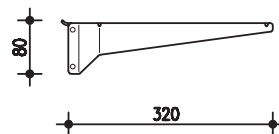
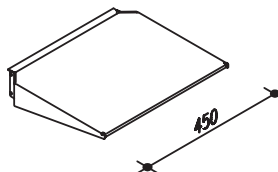

**Mensola**  
Étagère  
Shelf  
Ablagebrett  
Estante

**Y780**

**Y915**

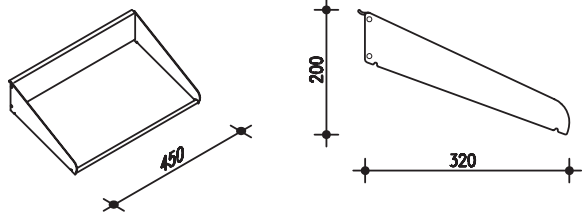

**Mensola inclinata**  
**Etagère inclinée**  
**Inclined shelf**  
**geneigte Konsole**  
**Estante inclinado**

**Y903**

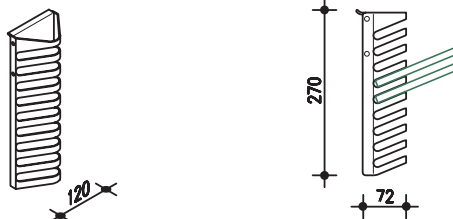

**Porta DVD**  
**Porte-DVD**  
**DVD-rack**  
**DVD-Träger**  
**Porta DVD**

**Y918**

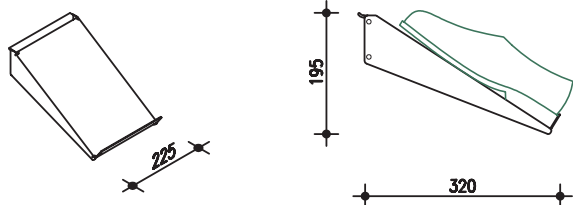

**Portascarpe**  
**Porte-chaussures**  
**Shoe rack**  
**Schuhschrank**  
**Portazapatos**

**Y916**

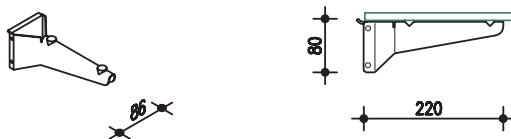

**Reggimensola per cristallo**  
**Support d'étagère en verre**  
**Crystal shelf-holder**  
**Glaskonsolenträger**  
**Sostén para estante de cristal**

**Y908**

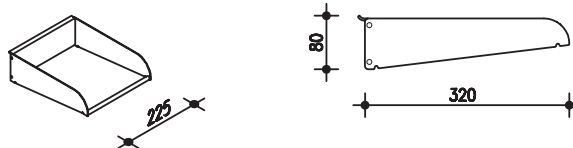

**Vaschetta UNI A4**  
**Bac UNI A4**  
**UNI A4 tray**  
**kleine Konsole UNI A4**  
**Bandeja UNI A4**

**Y904**

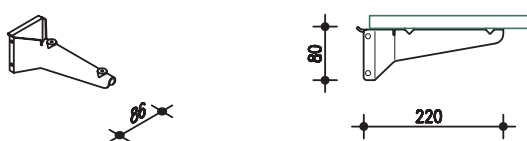

**Reggimensola per legno**  
**Support d'étagère en bois**  
**Wood shelf-holder**  
**Holzkonsoleträger**  
**Sostén para estante de madera**

**Y909**

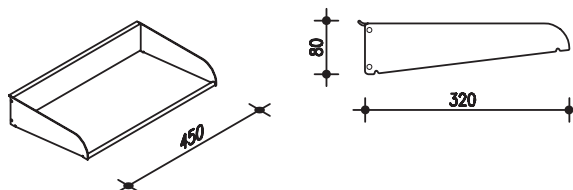

**Vaschetta UNI A3**  
**Bac UNI A3**  
**UNI A3 tray**  
**kleine Konsole UNI A3**  
**Bandeja UNI A3**

**Y919**

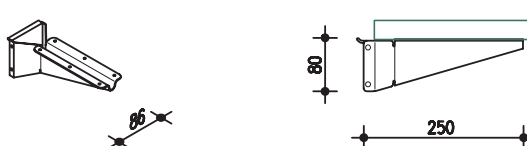

**Reggimensola per legno**  
**Support d'étagère en bois**  
**Wood shelf-holder**  
**Holzkonsoleträger**  
**Sostén para estante de madera**

**Y911**

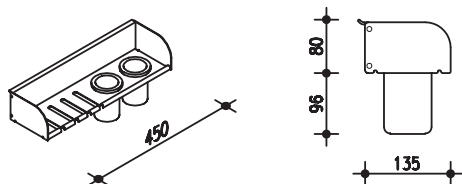

**Portapenne e timbri**  
**Porte-stylos et timbres**  
**Pen and stamp rack**  
**Stifte und Stempelhalter**  
**Portabolígrafos y sellos**

**Y905**

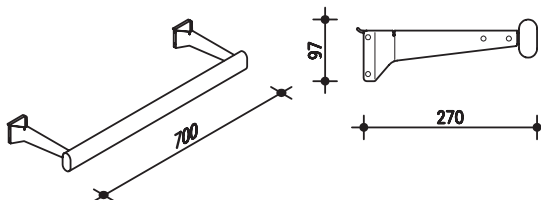

**Appendiabiti**  
**Tringle à vêtements**  
**Clothes rack**  
**Kleiderstange**  
**Perchero**

**Y910**

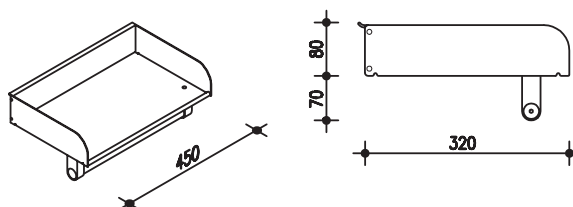

**Mensola appendiabiti**  
**Etagère porte-vêtements**  
**Clothes shelf**  
**Konsole mit Kleiderstange**  
**Estante con perchero**

**Y906**

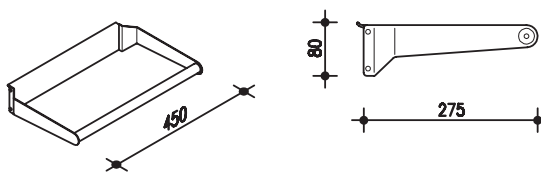

**Appendiabiti**  
**Tringle à vêtements**  
**Clothes rack**  
**Kleiderstange**  
**Perchero**

**Y913**

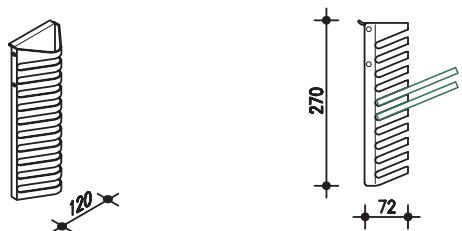

**Porta CD**  
**Porte-CD**  
**CD-rack**  
**CD-Träger**  
**Porta CD**

**Y907**

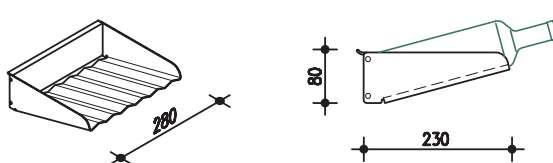

**Portabottiglie**  
**Porte-bouteilles**  
**Bottle holder**  
**Flaschenträger**  
**Portabotellas**

**Y912**

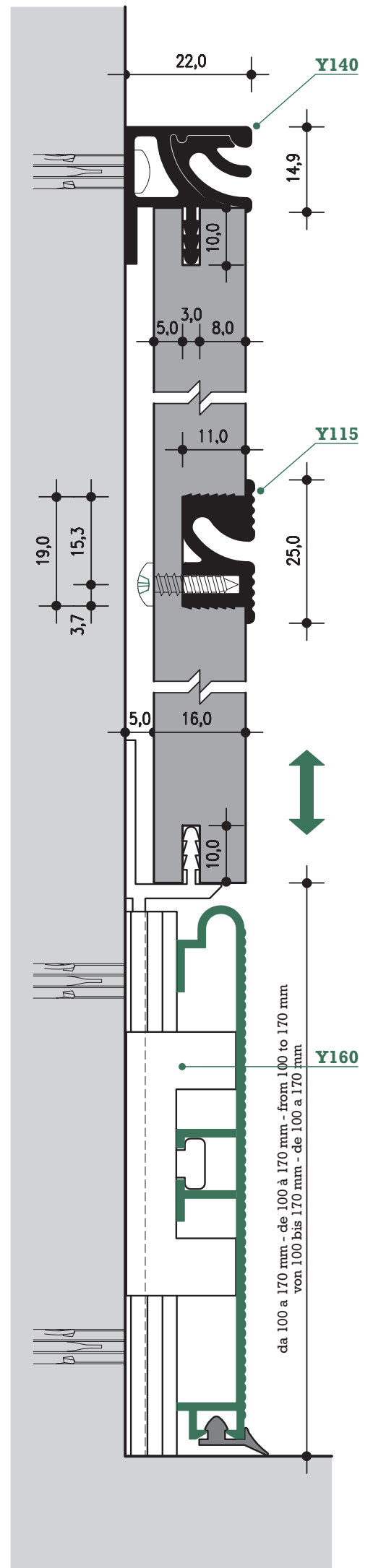
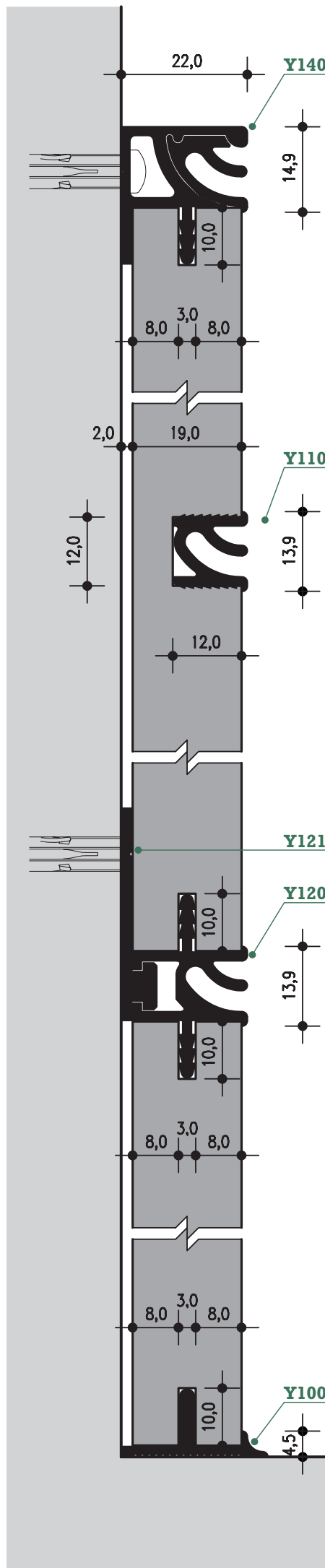
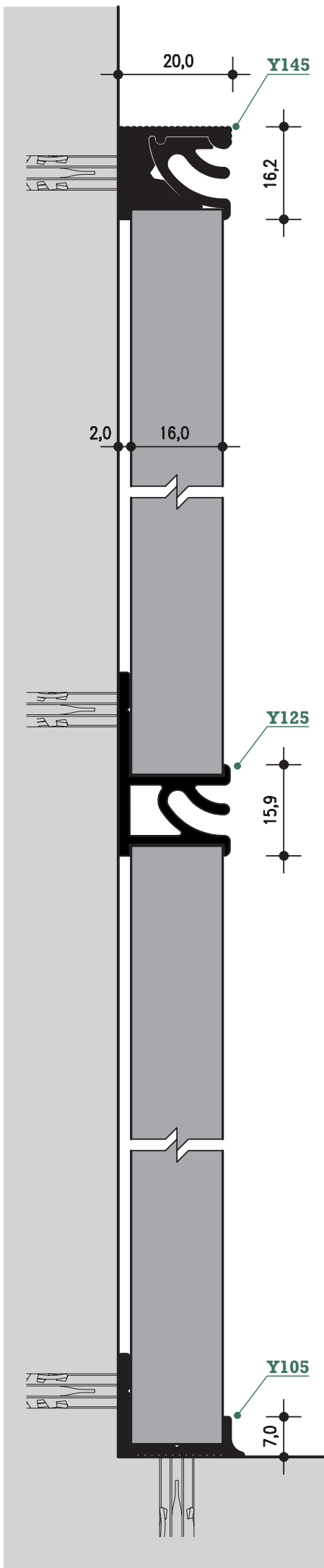

Nelle composizioni per cucina l'ampia gamma di accessori garantisce praticità e pulizia. Negli arredi per negozi o esposizioni offre la facilità di attrezzare pannelli e pareti divisorie con stile e semplicità.

Dans les compositions pour cuisine, une vaste gamme d'accessoires garantit praticité et propreté. Pour les agencements de magasins ou d'expositions, il est facile d'équiper panneaux et parois de division avec élégance et simplicité.

Die breite Auswahl an Zubehörteilen garantiert in den Küchenkompositionen, Zweckmäßigkeit und Reinlichkeit. In den Einrichtungen für Geschäfts- oder Ausstellungsräume bietet sie die leichte und stilgerechte Ausrüstung von Paneelen und Trennwänden.

In the kitchen compositions, the wide range of accessories ensures practicality and hygiene. In the furnishing solutions for shops or displays, it makes dressing panels and partitions in style easy.

En las composiciones para la cocina, la amplia gama de accesorios garantiza practicidad y limpieza. En las decoraciones para tiendas o exposiciones, permite equipar paneles y paredes divisorias con estilo y sencillez.

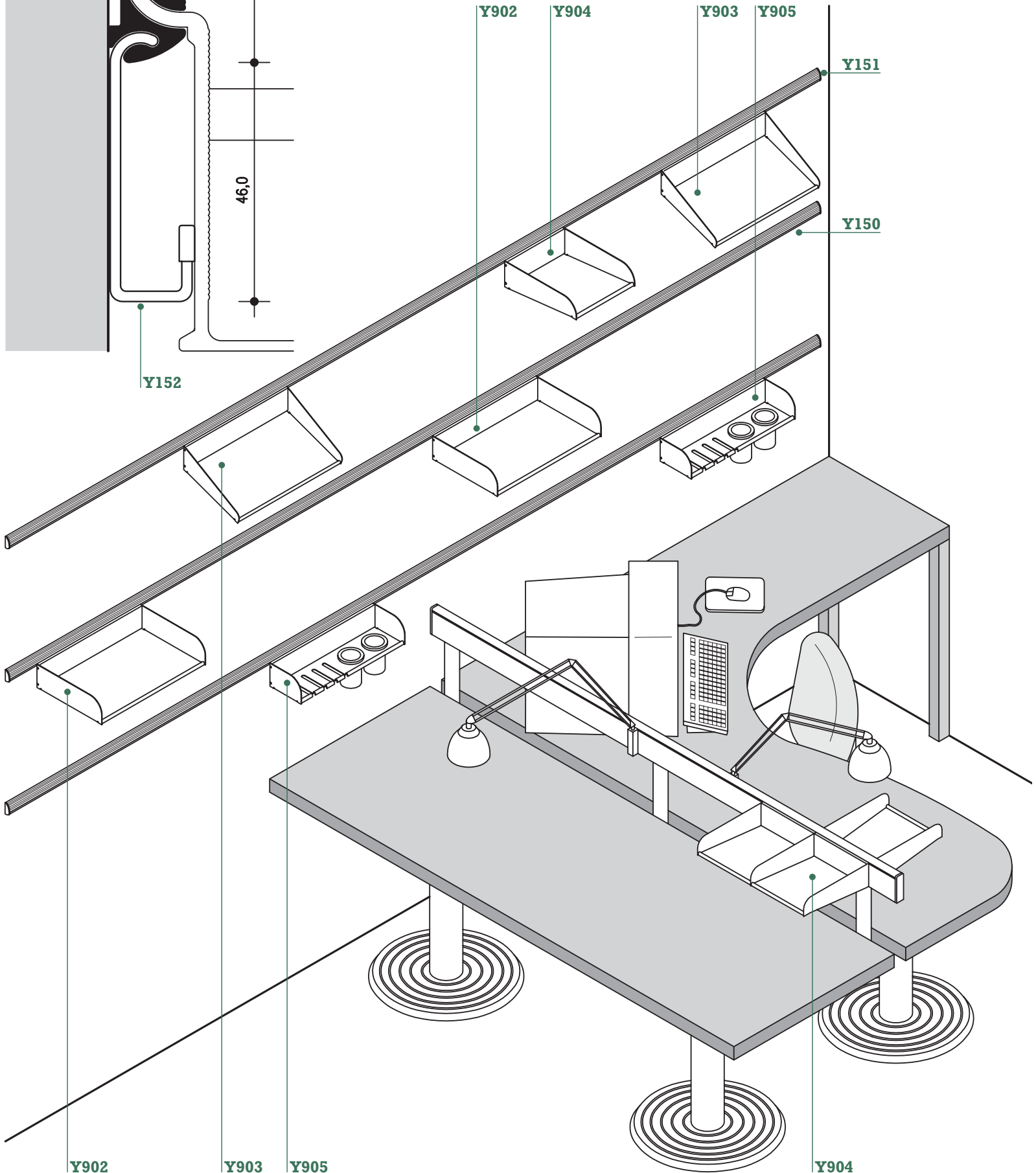
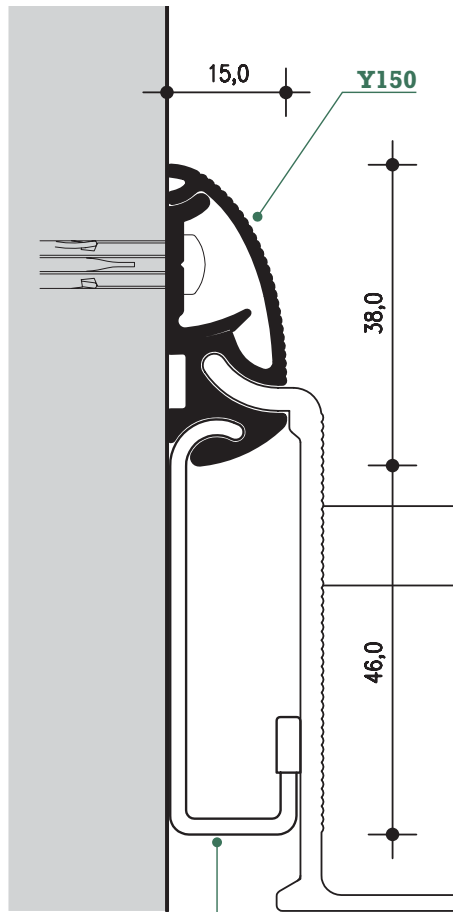

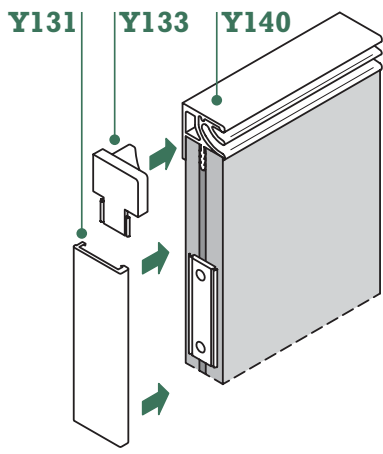

Y752

Y810

Y771

Y751

Y906

Y120

Y160

Y145

Y135

Y125

Y105

Y906

Y908

Y903

Nella versione a muro, oltre che per allestire angoli della casa, PARTY si rivela utile nell'arredo di uffici dove con rapidità si installano ripiani, appendiabiti, vaschette porta fogli e cancelleria.

La durezza dell'alluminio e le accurate finiture sono garanzia d'immagine.

Dans la version murale, non seulement PARTY sert à organiser des coins de la maison, mais elle s'avère utile à agencer des bureaux, où pourront être installés avec rapidité étagères, portemanteaux, bacs porte-papier et articles de bureau. La durabilité de l'aluminium et les finitions soignées sont l'image de marque de notre produit.

Besides fitting out the corners of the home, with the wall solution, PARTY proves to be useful in furnishing offices where shelves, clothes racks, paper and stationery trays are quickly installed. The sturdiness of aluminium and careful finish ensure your image.

Bei der Wand-Version zeigt sich PARTY nicht nur nützlich in der Ausstattung von Eckplätzen in der Wohnung, sondern auch in der Einrichtung von Büroräumen, wo sich schnell Fachböden, Kleiderstangen, Ablagen für Dokumente und Bürobedarf anbringen lassen.

Die Beständigkeit des Aluminiums und die sorgfältige Ausführung sind die Garantien für die Darstellung und deren Ausstrahlung.

El modelo de pared PARTY es útil para equipar ángulos de la casa y, también, para decorar oficinas ya que permite instalar con rapidez estantes, percheros, bandejas portapapeles y accesorios para elementos de papelería, en general. La larga vida del aluminio y los acabados cuidados representan una garantía para la imagen.